

**evolX Platform**



PRODUCTS &  
SOLUTIONS

# Coaxial Gearmotor



**EVOX** is Bonfiglioli's new geared motor platform; the EVOX family starts with the new **CP**.

**EVOX CP** is an helical in-line product designed with a smooth surface and a performance/value focus.

Its footprint aligned with market standards allows fitting your machine without changing the gear unit interface. Thanks to the wide range of versions/options and motor technology available in **Bonfiglioli's portfolio**, this new product can be adapted to any machine need.

Features	Benefits
Market standard footprint	Fits easily on every machine interface
Smooth surface	Easy-clean shape
Every mounting position available with the standard Product	Lower stock codes
High torque density for in-line technology	High roughness and performances
Reinforced radial/axial bearing option	Product ready for decentralized transmission
Feet & flange output & high speed ratios	Product ready for pumps & compressors

EVOX CP sizes	Nominal torque	Gear ratio range	Max radial loads	Max Compact Gearmotor Power	
	[Nm]		[N] <sup>1</sup>	[kW]	[hp]
07	55	2.8-81.2	1600	0.37	0.5
17	100	2.4-85.9	1770	0.75	1
37	200	2.3-133	4500	up to 1.5kW; Higher Powers are Coming Soon	up to 2hp; Higher Powers are Coming Soon
47	335	2.4-172	5000		
57	500	<b>Coming soon</b>			
67	650				

(1) Max performances @ 1400 rpm in input, Nominal output torque and radial load, applied in the middle of the o. shaft.  
This value could change with the gear ratio

# Asynchronous Low Voltage Motor



**EVox** BXN, MXN and MNN are asynchronous low voltage (<1000V) e-motors and brakemotors, developed in the sign of modularity, efficiency and reliability.

The aim of this product is to be compliant with your needs, both in standalone version and in a compact coupling with Bonfiglioli Gear Units.

Efficiency	Compact		IEC	Power	
	IE1	IE3	IE3	[kW]	[hp]
Series	MNN	MXN	BXN		
Poles	4	4	4		
	05MA	05MA	63MA	0,12	0,16
	05MB	05MB	63MB	0,18	0,25
	05MC	10MA	71MA	0,25	0,33
	10MA			0,25	0,33
	10MB	10MB	71MB	0,37	0,5
	10MC	20MA	80MA	0,55	0,75
	20MA			0,55	0,75
	20MB	20MB	80MB	0,75	1
		25S	90S	1,1	1,5
		25L	90L	1,5	2
		30LA	100LA	2,2	3
		30LB	100LB	3	4
		35M	112M	3,7	5
		40S	132S	5,5	7,5
		40M	132M	7,5	10

Coming soon

## Technical Features | EVOX CP Gear unit

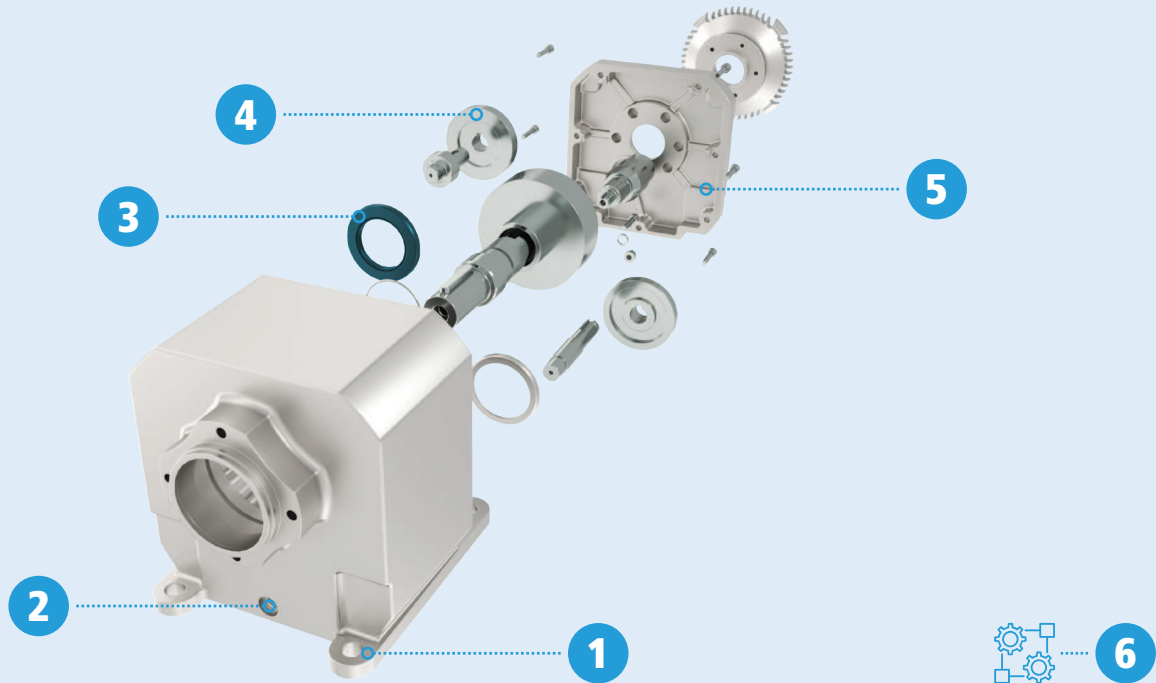

**1** MKT standard footprint

**2** Every mounting position possible with one product

With its unique oil level, this gear unit can be fitted on any position. This also means less plugs and leakages.

**3** Reliability focus for every standard component

Using more reliable components improves the reliability of the whole product.

**4** Efficiency and low noise gears set

These highly effective gears reduce oil heating, preventing its leakage through the seals.

**5** Product flexibility/modularity

Easy assembly with simple tools.

**6** Great set of versions and options

# Technical Features | EVOX Asynchronous E-Motor

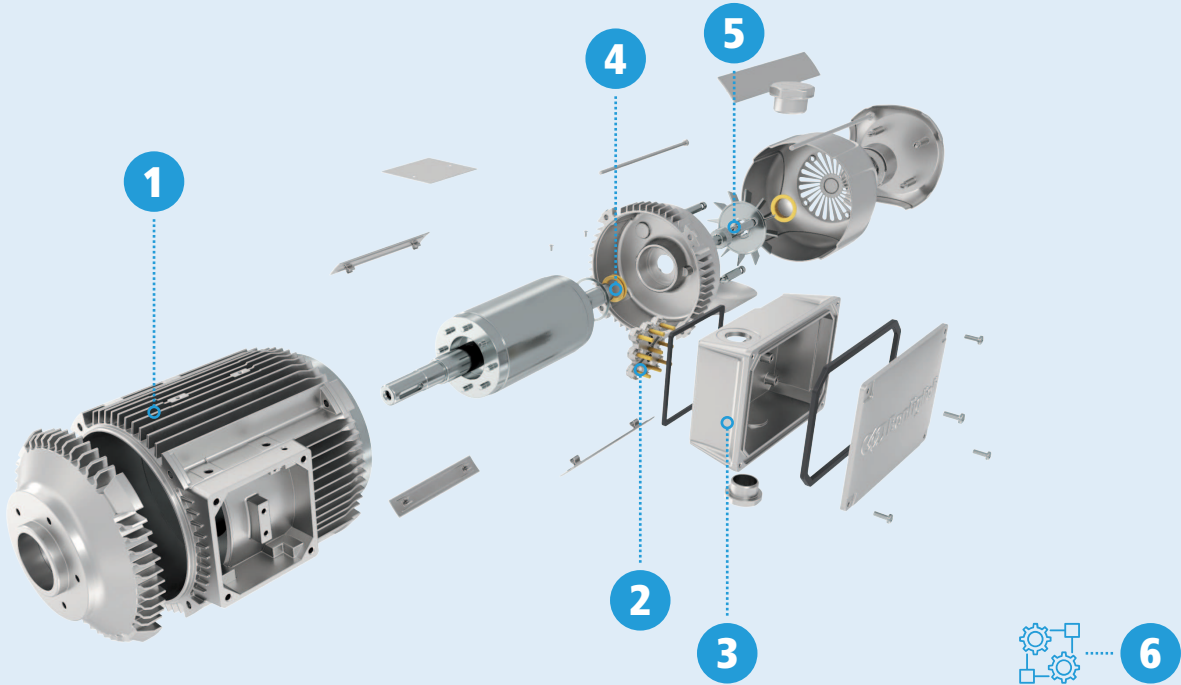

- 1** **Uncompromised IE3 Efficiency**  
 This motor is compliant with the most severe regulations in the world in terms of efficiency.
- 2** **One motor for EU, USA, India & Australia**  
 With its particular 9 PIN connection, by simply changing the plugs arrangement, you could get the right tension for most Countries as Standard.
- 3** **Reliability focus for every standard component**  
 Using more reliable components improves the reliability of the whole product.
- 4** **Rotating terminal box**  
 With this feature, you could rotate the terminal box in every position you need.
- 5** **Modular brakes, encoders and fans**
- 6** **Great set of versions and options**

# Versions | EVOX CP Gear Unit



These gear unit solutions can meet **all** basic **MKT needs**.  
**Soon to be followed by several other products.**

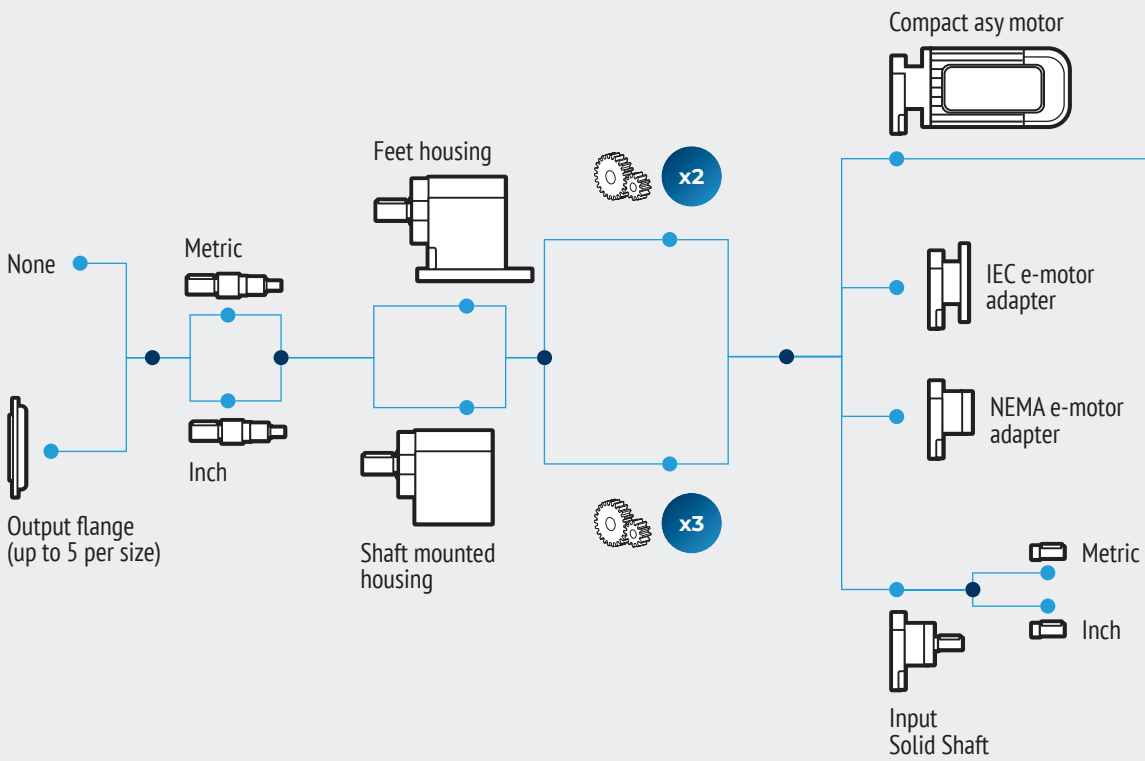



# Versions | EVOX Asynchronous E-Motor



Lots of e-motor versions available to perfectly match your application needs.

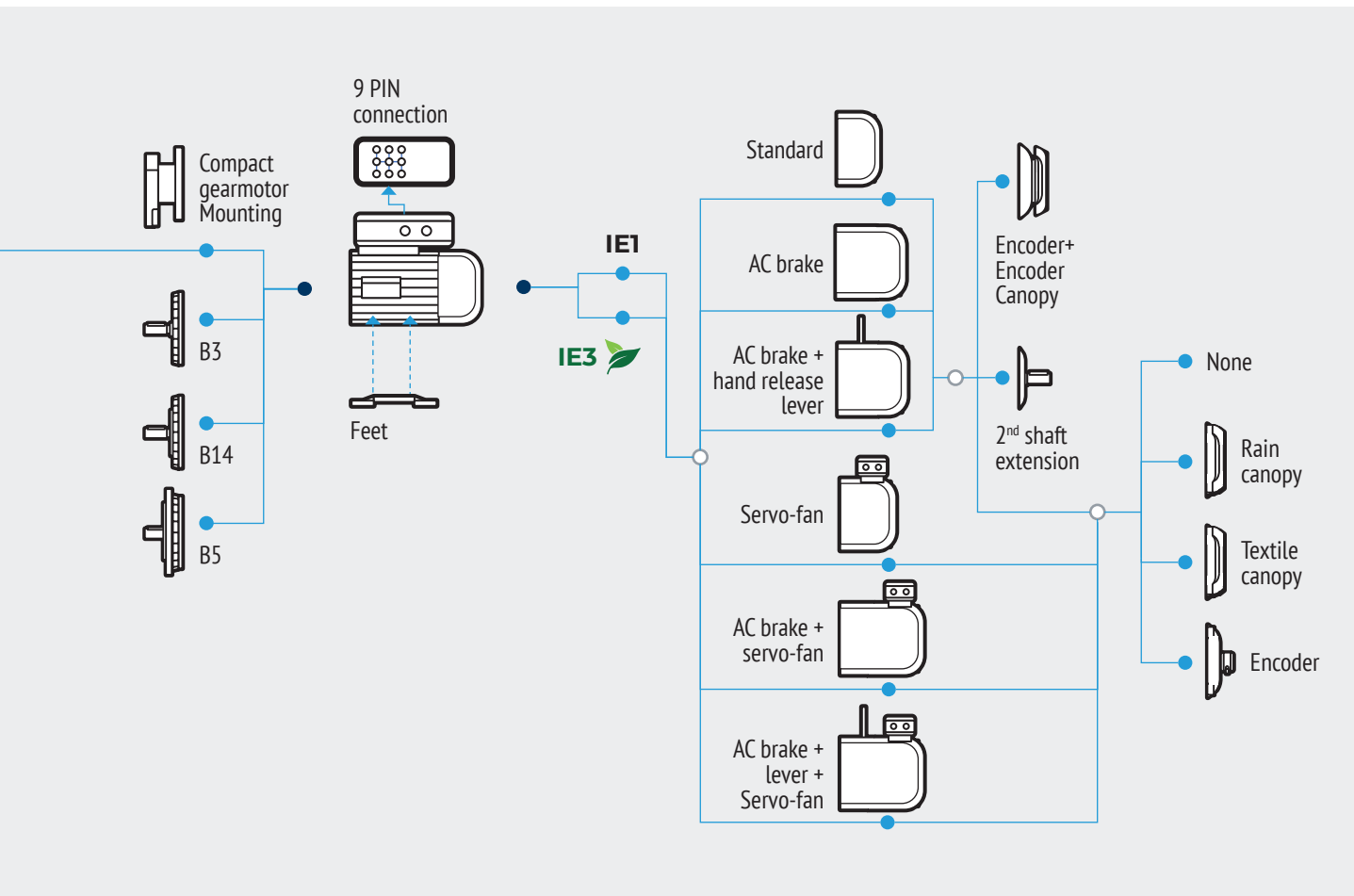

## With those features this product is suitable for several applications

- **Product fully interchangeable with MKT standard**
- **IE3 uncompromised efficiency**  
Making it technically ready for premium efficiency applications worldwide.



### High axial & radial loads options

Making this product suitable for screw conveyors and/or decentralized transmissions.



### Compact design

Making it compatible even with severe application constraints.

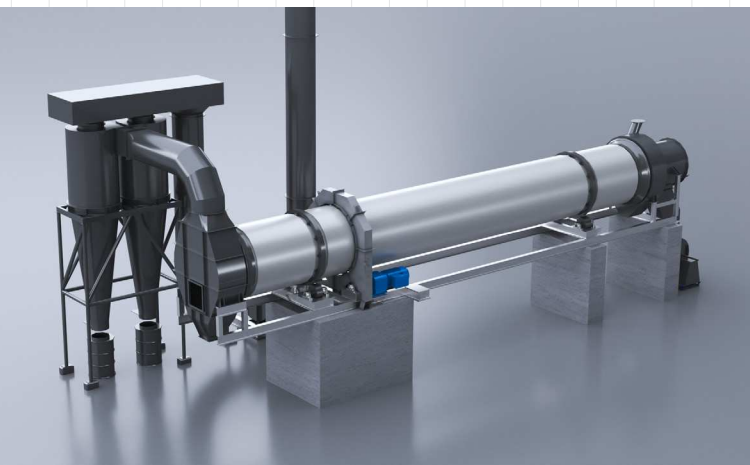

### MKT best in class by torque

Making the product with the highest torque density of its category.





# EVOX and Bonfiglioli inverters combinations enhance solutions benefits



## Smart conveyor



Features	Benefits
Advanced and accurate sensorless vector control providing high starting torque at low speed	Reducing current consumption at starting phase
Built-in PLC functions	Programming smart conveyor without PLC
Standby mode	Energy saving
Integrated monitoring tool	Inverter failure prevention and diagnostics analysis

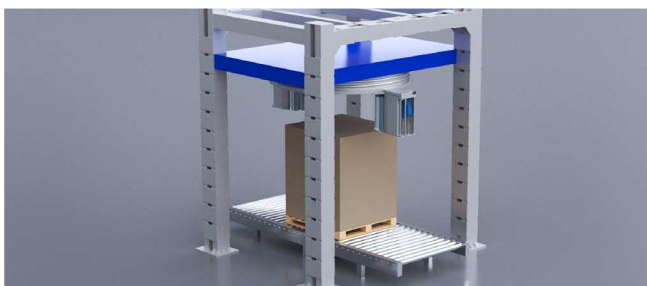

## Wrapping machine



Features	Benefits
Advanced and accurate sensorless and closed loop vector control	Pallet wrapping machine soft start and soft stop
PI control with advanced derivative control	Optimized film tension control
Configurable position and speed control via parameters	Variable lift speed and up/down controls
Built-in PLC functions	Wrap cycle adjustment
Possible sync between several drives	Machine can operate without any PLC

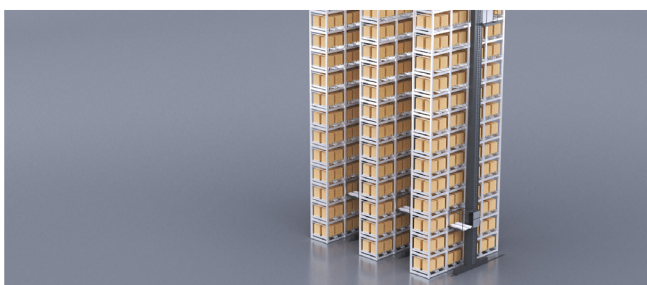

## Vertical automatic storage



Features	Benefits
Wide range of Functional Safety functionalities (SBC; STO; SS1; SLS; ...)	Minimized risks of damages to persons, property and environment.
Application monitoring	Diagnostics, alarm management, predictive maintenance
See Bonfiglioli BMC  < Connectable with Motion Controller (CSP mode)	<ul style="list-style-type: none"> <li>Machine complete integration</li> <li>One-stop shop</li> </ul>
Different encoder options available	Flexible application
Mobile & Desktop user-friendly GUI and Bluetooth inverter connection	<ul style="list-style-type: none"> <li>Plug &amp; Play solution</li> <li>Easy troubleshooting</li> </ul>

## Global Presence



Bonfiglioli is a market force with a presence spanning 22 countries on 5 continents. Our organization makes the most of geographic proximity to offer complete solutions combining efficiency and competence.



3780  
EMPLOYEES



20  
BRANCHES



13  
PLANTS



550  
DISTRIBUTORS



80  
COUNTRIES

## We Are a Global Company

Thanks to an international network of sales branches and closely interconnecting production plants, we can guarantee the same high standards of Bonfiglioli quality anywhere at any given time. Aware that our direct presence in local markets is the key to long-lasting success, our family includes 20 sales branches, 13 production plants and more than 500 distributors around the world.

**Our organization is always close by, offering complete and efficient solutions and supporting our customers with dedicated services, such as co-engineering or after-sales assistance.**



# Bonfiglioli Worldwide Locations

## Australia

### **Bonfiglioli Transmission (Aust.) Pty Ltd.**

2, Cox Place Glendenning NSW 2761  
Locked Bag 1000 Plumpton NSW 2761  
Tel. +61 2 8811 8000

## Brazil

### **Bonfiglioli Redutores do Brasil Ltda.**

Travessa Cláudio Armando 171 - Bloco 3 - CEP 09861-730  
Bairro Assunção - São Bernardo do Campo - São Paulo  
Tel. +55 11 4344 2322

## China

### **Bonfiglioli Drives (Shanghai) Co. Ltd.**

#68, Hui-Lian Road, QingPu District,  
201707 Shanghai  
Tel. +86 21 6700 2000

## France

### **Bonfiglioli Transmission s.a.**

14 Rue Eugène Pottier  
Zone Industrielle de Moimont II - 95670 Marly la Ville  
Tel. +33 1 34474510

## Germany

### **Bonfiglioli Deutschland GmbH**

Sperberweg 12 - 41468 Neuss  
Tel. +49 0 2131 2988 0

### **Bonfiglioli Vectron GmbH**

Europark Fichtenhain B6 - 47807 Krefeld  
Tel. +49 0 2151 8396 0

### **O&K Antriebstechnik GmbH**

Ruhrallee 8-12 - 45525 Hattingen  
Tel. +49 0 2324 2050 1

## India

### **Bonfiglioli Transmissions Pvt. Ltd.**

#### **Mobile, Wind**

AC 7 - AC 11 Sidco Industrial Estate  
Thirumudivakkam Chennai - 600 044  
Tel. +91 844 844 8649

#### **Industrial**

Survey No. 528/1, Perambakkam High Road Mannur Village,  
Sriperumbudur Taluk Chennai - 602 105  
Tel. +91 844 844 8649

#### **Industrial**

Plot No.A-9/5, Phase IV MIDC Chakan,  
Village Nighoje Pune - 410 501  
Tel. +91 844 844 8649

## Italy

### **Bonfiglioli S.p.A.**

#### **Headquarters**

Via Bazzane, 33 - 40012 Calderara di Reno  
Tel. +39 051 647 3111

#### **EVO - Industrial**

Via Bazzane, 33/A - 40012 Calderara di Reno  
Tel. +39 051 6473111

#### **Mobile, Wind**

Via Enrico Mattei, 12 Z.I. Villa Selva - 47100 Forlì  
Tel. +39 0543 789111

### **Bonfiglioli Riduttori S.p.A.**

Via Bazzane, 33 - 40012 Calderara di Reno  
Tel. +39 051 6473111

### **Bonfiglioli Mechatronic Research S.p.A**

Via Unione 49 - 38068 Rovereto  
Tel. +39 0464 443435/36

## New Zealand

### **Bonfiglioli Transmission (Aust.) Pty Ltd.**

88 Hastie Avenue, Mangere Bridge, 2022 Auckland  
PO Box 11795, Ellerslie  
Tel. +64 09 634 6441

## Singapore

### **Bonfiglioli South East Asia Pte Ltd.**

8 Boon Lay Way, #04-09,  
8@ Tadehub 21, Singapore 609964  
Tel. +65 6268 9869

## Slovakia

### **Bonfiglioli Slovakia s.r.o.**

Robotnícka 2129  
Považská Bystrica, 01701 Slovakia  
Tel. +421 42 430 75 64

## South Africa

### **Bonfiglioli South Africa Pty Ltd.**

55 Galaxy Avenue, Linbro Business Park, Sandton,  
Johannesburg, 2090 South Africa  
Tel. +27 11 608 2030

## Spain

### **Tecnotrans Bonfiglioli, S.A.**

Pol. Ind. Zona Franca, Sector C, Calle F, nº 6  
08040 Barcelona  
Tel. +34 93 447 84 00

## Turkey

### **Bonfiglioli Turkey Jsc**

Atatürk Organize Sanayi Bölgesi, 10007 Sk. No. 30  
Atatürk Organize Sanayi Bölgesi, 35620 Çiğli - Izmir  
Tel. +90 0 232 328 22 77

## United Kingdom

### **Bonfiglioli UK Ltd.**

Unit 1 Calver Quay, Calver Road, Winwick  
Warrington, Cheshire - WA2 8UD  
Tel. +44 1925 852667

## USA

### **Bonfiglioli USA Inc.**

3541 Hargrave Drive  
Hebron, Kentucky 41048  
Tel. +1 859 334 3333

## Vietnam

### **Bonfiglioli Vietnam Ltd.**

Lot C-9D-CN My Phuoc Industrial Park 3  
Ben Cat - Binh Duong Province  
Tel. +84 650 3577411



We have a relentless commitment to excellence, innovation and sustainability. Our team creates, distributes and services world-class power transmission and drive solutions to keep the world in motion.

#### **HEADQUARTERS**

Bonfiglioli S.p.A.  
Via Bazzane, 33  
40012 Calderara di Reno  
Bologna (Italy)  
[www.bonfiglioli.com](http://www.bonfiglioli.com)

